



your fire place

# JAYLINE IS550 INSERT WOOD FIRE

## INSTALLATION & OPERATION INSTRUCTIONS

*Please leave this information with the appliance*



SEE INSIDE TO REGISTER  
FOR YOUR 15 YEAR WARRANTY.

## ***Congratulations on the purchase of your Jayline wood fire.***

***Please read this installation and operation manual carefully.***

***The installation of this fire must comply with the Installation Standard AS/NZS 2918:2001 as well as any additional local requirements.***

***Please ensure you have all relevant permits prior to installation.***

***Keep this booklet as a reference guide.***

## **INSTALLATION OF YOUR JAYLINE WOOD FIRE**

Jayline recommends you use a suitably qualified installation technician to install your fire. Your dealer or heating specialist will be able to help with recommendations as well as advise on permits/consents required for the installation in your area.

Please follow carefully all dimensions and recommendations provided on the individual specification sheet for your model of heater as these dimensions comply with the required New Zealand standard (AS/NZS 2918:2001).

***As safety and emissions performance can be affected by altering the appliance, no modifications are allowed without the written permission from the manufacturer.***

### **PRE-INSTALLATION**

Prior to installing your Jayline Insert into a fireplace cavity, it is important that certain clearances and other requirements are complied with as detailed below:

### **FIREPLACE CAVITY**

- \* The chimney must be swept.
- \* Check for cracks and overall condition. If repairs are necessary, they must be carried out by a suitably qualified technician.
- \* Check the cavity dimensions to ensure the insert will fit. It is usually necessary to remove the bricks from the lower fireplace cavity.
- \* The base of the fireplace on which the Jayline Insert will rest must be level. If not, it should be leveled using mortar.
- \* If a timber or combustible mantle shelf exists above the fireplace opening, it should be a minimum distance above the top of the floor protector. The minimum distance is 1175mm. If less than the minimum specified, a deflector or heat shield will be required to be under the mantle shelf.



## **Installation requirements for Jayline IS550 fireplace insert and flue system, where timber framing is less than 50mm from the chimney structure.**

The installation should be carried out by a suitably qualified installation technician who will ensure the following:

- \* The minimum clearances determined by tests in accordance with AS/NZS 2918:2001 are complied with to prevent overheating of nearby combustibles.
- \* The minimum opening size of 590mm wide x 570mm high x 481mm deep is available when the firebricks are removed. These measurements exclude the 30mm insulating blanket fitted to the sides, back & top of the outer casing. Please make an allowance for the blanket where possible as its recommended to improve heater efficiency.
- \* If the fireplace opening is in a heat sensitive wall, a non-metallic heat resistant material shall extend not less than 50mm beyond each side of the appliance and 150mm beyond the top of the appliance.
- \* A clearance of at least 1 metre between the front of the appliance and building structure, or any other substantial immovable object.
- \* The ash floor protector of non-combustible material is provided, extending not less than the dimensions shown in the specification sheets for this appliance.
- \* A fireplace shall not be connected to a flue common with an open fireplace.
- \* The flue pipe must be fitted up to, and above the chimney top. The space between the flue pipe and the chimney must be vented at the top. The area of this vent must not be less than 10,000mm<sup>2</sup>. The vent must be fitted with means to prevent significant water and debris from entering the cavity, or vent area. The flue must be free to move up & down 25mm or more due to the expansion and contraction of the flue under normal use.
- \* Seismic restraints consisting of two M6 x 50mm dynabolts (or equivalent) are fitted through the front edge of the outer cabinet base brackets, and into the masonry base below, before the fascia is fitted.

## **INSTALLATION**

Establish the masonry cavity is suitable as above.

- \* Unpack the fire box / outer casing and fascia and check there is no damage.
- \* Read the specification sheets and installation instructions.
- \* With the top front outer case panel removed, and the door removed, slide the fire box / outer case into the prepared cavity and centralise (including the outer case insulating blanket).
- \* Ensure the folded edges of the outer case are flush with the front of the cavity, allowing for any fibreglass seal that may be required as an air seal between the fascia and masonry.
- \* The S/S flue pipes must be sealed & fastened with at least 3 x S/S rivets each (follow the flue manufacturer's instructions) .
- \* Lower the flue system down the cavity and into the flue spigot using a hi-temp sealant (an offset may be required in some cases).
- \* Drill and secure the flue pipe into the flue spigot using a S/S self-tapping screw.
- \* Re-check the outer case is still flush with the front of the cavity, then drill & secure the seismic restraints as above.



- \* Re-fit the top front outer case panel (including the top insulating blanket).
- \* Prior to fitting the fascia, remove any combustible packaging that may have entered the cavity or outer casing while installing the firebox into place.
- \* Do not lift the fascia with your fingers under the louvres.
- \* The fascia is fitted to the firebox outer casing, by pressing the fascia onto the ball studs fitted to the outer casing.
- \* Remove the packaging that holds the baffle in place.
- \* Re-fit the door.
- \* Fit the control knob and ensure a smooth operation.

**Remember:**

- The flue pipe penetrating the chimney must continue to the minimum length of 4.6m from the top of the floor protector to the cowl.
- Flue exiting more than 3 metres from the ridgeline must terminate no less than 1 metre above the roof penetration (see diagram 1 below).
- Where the top of the flue pipe is more than 2 metres above its highest fixing point, it must be stayed against high winds.

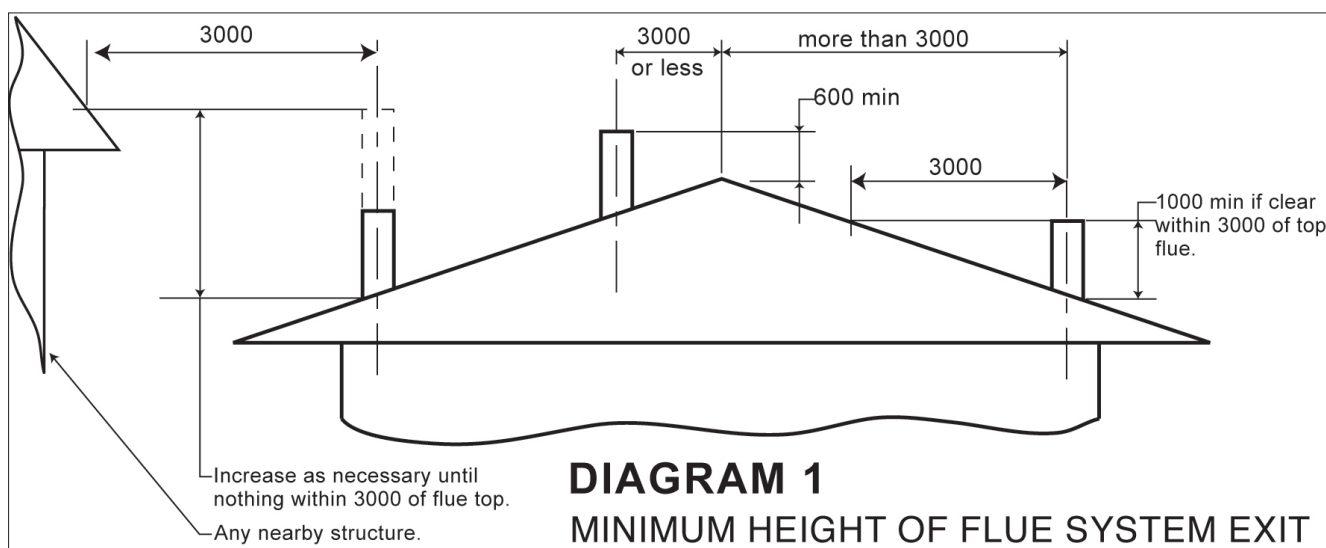

**FITTING SEISMIC RESTRAINT**

The Floor Protector must be mechanically fixed to the floor by bolting or screwing.

**Note:** Floor Protector to be fixed by gluing when on a concrete floor that may have water pipes or electrical wires present. The appliance can then be bolted to the floor protector with two 6mm x 50mm dynabolts (or equivalent).

**BAFFLE**

Before lighting your appliance for the first time, make sure the baffle is in the correct position being as far to the rear as possible.



## REDUCING CLEARANCES TO COMBUSTIBLE WALLS

In the event it is necessary to reduce the clearances to combustible surfaces, it must always be done in accordance with the safety standard AS/NZS2918:2001 Section 3, Tables 3.1 and 3.2

The shielding shall be constructed from a heat resistant material. The shield must be fixed to the surface that requires protection and NOT the heater.

The standard allows three options to reduce the stated clearances:

Single Layer of continuous material with minimum Air Gap of 12mm to achieve a clearance factor of 0.40

Single layer of continuous material with minimum Air Gap of 25mm to achieve a clearance factor of 0.30

Two spaced Layers of continuous material with minimum Air Gap of 12mm + 12mm to achieve a clearance factor of 0.20

The shielding must be open at the top and bottom (vented) to allow a continuous air flow. It is this flow that keeps the surface requiring protection cool. Fixings should not impede this air flow.

The shielding needs to go far enough along and up the wall so that the original side and rear required clearances are not compromised. As the flue is now closer to the wall the shielding should also protect the wall from the flue pipe.

### **Example:**

- Side wall clearance for the Jayline FR300 is 290mm
- A 12mm gapped shield on the wall with a factor of 0.40
- Calculate:  $290\text{mm} \times 0.40 = 116\text{mm}$  (This is the new sidewall minimum clearance)
- The shielding needs to be large enough that none of the original clearances of 290mm are compromised.



## WARNINGS

- 1. WARNING:** THE HEATER AND FLUE SYSTEM SHALL BE INSTALLED IN ACCORDANCE WITH AS/NZS 2918:2001 AND THE APPROPRIATE REQUIREMENTS OF THE RELEVANT BUILDING CODE OR CODES.
- 2. WARNING:** APPLIANCES INSTALLED IN ACCORDANCE WITH THIS STANDARD SHALL COMPLY WITH THE REQUIREMENTS OF AS/NZS 4013:1999 WHERE REQUIRED BY THE REGULATORY AUTHORITY, i.e. THE APPLIANCE SHALL BE IDENTIFIABLE BY A COMPLIANCE PLATE WITH THE MARKING 'TESTED TO AS/NZS 4013:1999. ANY MODIFICATION OF THE HEATER THAT HAS NOT BEEN APPROVED IN WRITING BY THE TESTING AUTHORITY IS CONSIDERED TO BE IN BREACH OF THE APPROVAL GRANTED FOR COMPLIANCE WITH AN/NZS 4013:1999.
- 3.** PLEASE ENSURE THAT ONLY COMPONENTS APPROVED BY JAYLINE ARE USED FOR THE INSTALLATION as substitutes may adversely affect performance and might nullify compliance with the requirements of AS/NZS 2918:2001.  
**CAUTION:** MIXING OF HEATER OR FLUE SYSTEM COMPONENTS FROM DIFFERENT SOURCES OR MODIFYING THE DIMENSIONAL SPECIFICATION OF COMPONENTS MAY RESULT IN HAZARDOUS CONDITIONS. WHERE SUCH ACTION IS CONSIDERED, THE MANUFACTURER SHOULD BE CONSULTED IN THE FIRST INSTANCE.
- 4. CAUTION:** CRACKED AND BROKEN COMPONENTS, e.g. GLASS PANELS OR CERAMIC BRICKS MAY RENDER THE INSTALLATION UNSAFE.

Any variation from these installation instructions or any doubts about them must be checked against the requirements of the AS/NZS 2918:2001.



## CORRECT OPERATION OF YOUR JAYLINE WOOD FIRE

**Simply by burning your Jayline fire correctly, you can improve efficiency, reduce fuel consumption and minimise air pollution.**

**Please note:** Wood with a moisture content of 25% or less is the only approved wood to use in Clean Air Zones. Only softwoods should be used in the Canterbury Clean Air Zones.

### STARTING A NEW FIRE

**Please note:** If lighting the fire for the first time, dust fire, glass, trim and flue before firing to avoid particles sticking or discolouring. Once fired, some smoke and vapour will be released as the VHT painted surfaces enter the final curing process. Open all windows and doors while running the fire on high for up to 3 hours. People with respiratory, heart or other relevant medical conditions should avoid inhaling vapours during the curing process. All VHT paint will cure at the highest temperature achieved and will produce smoke again if this temperature is exceeded.

To start and maintain a good fire you will need the following ingredients:

1. A small quantity of newspaper (do not use coloured or coated paper);
2. A packet of firelighters (optional)
3. A quantity of finely split, dry soft wood kindling in a variety of sizes; and
4. Seasoned firewood split into a range of piece sizes.

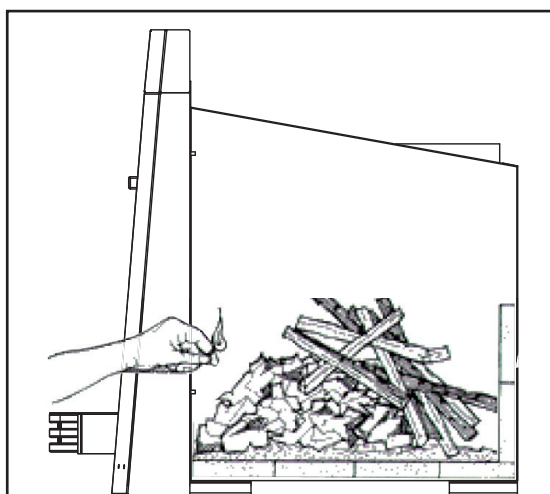

#### TO BUILD A QUICK, HOT FIRE

*Use plenty of crumpled newspaper and dry, finely-split kindling. Set the air control fully open. Light the newspaper near where the combustion air enters the firebox. When a kindling fire is built properly, you should expect fast ignition and no smouldering.*

The first step is to crumple half a dozen sheets of newspaper and put them just inside the firebox. The amount of newspaper you need will depend on the firebox size, and the dryness and fineness of the kindling you are using. The drier and finer the kindling, the less newspaper you need. Many people make the mistake of using too little newspaper. Be generous with the newspaper and you will have more success. Putting some firelighter halves under the newspaper can also help sustain firebox temperature until the wood is burning.

On top of the paper place 10 to 15 pieces of finely split, dry kindling. Softwoods, such as cedar or pine, make good kindling. Ideally, the kindling should be placed on the newspaper so that the combustion air reaches the newspaper fast where you ignite it. It is also a good idea to add two or three very small pieces of firewood to the kindling load before lighting.



Set the air control to fully open, light the firelighters or the newspaper and close but do not latch the door. After about 5-10 minutes, when the wood is flaming brightly, latch the door (some longer flue installations may require door to be left unlatched for up to 15 minutes until the flue system is warm and producing strong draught. Since leaving the door open slightly can cause dangerously high temperatures, never leave the woodstove unattended while starting the fire.

When the flames from the kindling load just begin to subside, add several small pieces of firewood. Try to avoid smothering the fire with the new pieces. Placing the pieces on the burning kindling can help prevent smothering. Your Jayline heater requires approximately 45-60 minutes to preheat the steel firebox before it can effectively emit heat into the room. A well maintained, hot fire will reduce the preheat cycle.

### REKINDLING A FIRE FROM CHARCOAL OR EMBERS

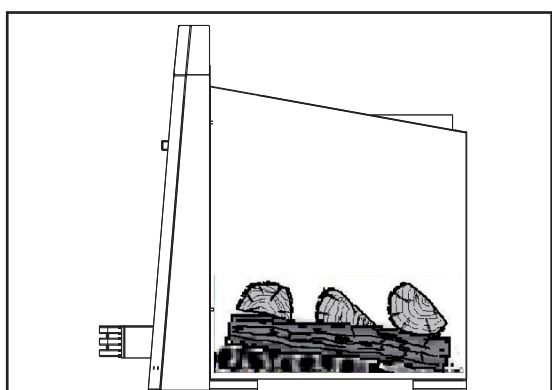

#### TO REKINDLE A FIRE FROM HOT COALS

*Rake the charcoal evenly. Place small pieces of wood on and behind the coals. Open the air inlets fully and leave them open until the pieces of wood are well charred. This illustration shows the arrangement of pieces for an extended fire.*

Embers found at the back of the firebox should be raked evenly around the fire box. If only a small amount of embers remain, you will have to start with kindling. If there is a good quantity of glowing embers to work with, place at least three, and preferably more than five pieces of small firewood on the embers. Open the air inlets fully and close the door.

If everything is just right, fast ignition of the new load should be expected. Allow the fire to burn with bright turbulent flames until the wood is completely alight. This usually takes between 15 and 30 minutes, depending on the size of the pieces and the moisture content of the wood. When the wood is burning well, reduce the air setting to produce the amount of heat and length of burn desired. Reducing the air control setting in two or three stages will result in less air pollution because the fire will not have to recover from the single, large reduction in air supply.

The most important rule is **NEVER LET THE FIRE SMOULDER**. As long as there is solid wood in the firebox, there must be flames present or the unburned gases will escape, both reducing efficiency and increasing air pollution.

Always open the fire door slowly to allow fresh air to enter and maintain the smoke path. If you open the door too quickly, smoke can puff out.





## SOME OTHER USEFUL TIPS

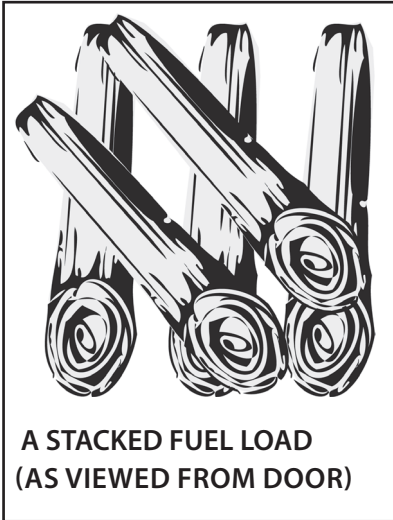

**Fuel load geometry:** Small pieces of firewood arranged loosely in a crisscross pattern (loaded front to back) burn quickly because the combustion air can reach all the pieces at once. Larger pieces placed a little more compactly burn slower. Once your heater has reached maximum temperature, it is more efficient to top up frequently with about 25% of a full load rather than let the fire die down and need to completely refill it.

**Fire in cycles:** Don't expect perfectly steady heat output from your Jayline heater. Solid fuel heaters burn in cycles. A cycle is the time between the ignition of a load from charcoal and the consumption of the load back to a coal bed. Plan the firing cycles around your household routine. If someone is home to operate the heater, build a small hot fire. If you must be away from the house during the day, build a long-burning fire.

**The small, hot fire:** A small, hot fire is a small amount of wood burned quickly. Use it when you just want to take the chill off the house. The small hot fire technique eliminates the smouldering fires that are common when people don't need their heater running hot all the time, like in spring and autumn. To build a small hot fire, rake the embers evenly in the firebox and place several small pieces of firewood on it. The bottom layer should be placed to ensure that combustion air can flow over the embers and along the length of the pieces of wood (loaded front to back). The next layer should be stacked as per the loading geometry. Open the air inlet to produce a hot, bright fire. After approximately 15–20 minutes the air supply can be reduced slightly as the fire progresses, but never enough to extinguish the flames. When only charcoal remains, the air supply can be reduced further to prevent cooling the ember bed. Reload with small pieces often (loaded front to back), as full loads will smother the ember bed.

**The long-burning fire:** To achieve a long burning fire, rake the embers evenly, as with the small hot fire, and use larger and more pieces of wood. Place the pieces in a similar pattern to the small hot fire, using more pieces and larger pieces (especially the top layer). Always make certain that there is a gap between the pieces to ensure that the combustion air can reach all pieces. Open the air inlets fully for between 15 to 30 minutes depending on load size and fuel moisture content. When the fire is burning fiercely (at least 15 minutes), reduce the air control in stages to the desired level. This allows you to turn down the air control and still maintain a clean-burning fire.

**REMEMBER: NEVER LET THE FIRE SMOULDER.**



**Preventing creosote build-up:** Creosote is a tar-like substance that builds up when the organic compounds in smoke condense onto cooler flue surfaces. Left to build up over time, creosote will restrict the airflow of the flue and impair the performance of your heater. The production of smoke is at its highest when a fresh fuel load is added or when the air control is at its lowest position. The most effective way to control the creosote formation is to burn the heater so as to ensure as complete combustion as possible and at the same time promoting higher flue temperatures. Smouldering fires should always be avoided.

The amount of charcoal in the ash is often a good indicator of how well you are operating the heater. If there is no charcoal and only very fine ash, then you are doing an excellent job. If there is a lot of charcoal you may be turning the combustion air down too soon after refuelling, or not raking the charcoal to the combustion air inlet, or turning the combustion air down too low to support efficient combustion, or all of the above.

**REMEMBER:** *THE HOTTER THE FIRE, THE LESS CREOSOTE FORMATION.*

When you have mastered the techniques for efficient wood burning, here is what you should see:

1. When wood burns it should be flaming until only charcoal remains. If there are no flames, something is wrong.
2. Firebricks in the firebox should be tan in colour, never black.
3. Steel parts in the firebox should be light to dark brown, never black and shiny.
4. With seasoned wood, correct air settings and proper loading arrangement you should expect quick ignition of a new load of wood - the bottom pieces should be flaming by the time the door is closed.
5. The glass door should be clear. A discoloured glass indicates that the wood is too wet or the air control has not been left open long enough.
6. The exhaust coming from the top of the flue system should be clear or white. A plume of blue or grey smoke indicates smouldering, inefficient combustion, air pollution and probably low operating temperatures.



Correctly installed and operated, Jayline solid fuel heaters do not spill smoke into the house. There are three main reasons why some woodstoves smoke:

**Bad installation design:** Incorrect flue installation, resulting in low flue temperatures and low draught, can make a wood heater more likely to spill smoke. For example, each elbow in the flue pipe assembly slows down the flow of gases and causes a small restriction to flow. When a flue system includes more than one elbow, the restriction can be enough to cause spillage.

**Extreme negative pressure in the house:** Energy efficiency practices and new building code rules are making our houses more and more airtight. This makes the houses energy efficient, but also makes them more sensitive to negative pressure when air is exhausted from the house. Large, fan-forced exhaust ventilators, like down-draught-type kitchen stove exhausts, can cause extreme negative pressure in the house when they are operating. Because new houses are tightly sealed, there are few holes to allow replacement air to enter, and the house pressure becomes negative. This negative pressure works against flue system draught. In severe cases, the negative pressure in the house overcomes the flue system draught and the appliance begins to spill smoke, especially when a fire is started or when it dies down to coals. To prevent this extreme negative pressure, one option is to open a window slightly to allow combustion air into the room.

**Improper heater firing technique:** When a solid fuel heater is starved for air it smoulders, producing a relatively cool, smoky fire. The temperatures throughout the system are low. During a smouldering fire, the flue system will not be receiving the hot gas it needs to produce strong draught. When the heater door is opened, smoke will spill into the room. A smouldering fire is the single most common reason for smoke spillage and totally unnecessary. By using the suggestions on proper firing technique earlier in this document, you will be able to avoid these smouldering fires.



## **PURCHASING THE FIREWOOD**

The quality of the firewood you burn can have a dramatic effect on the efficiency and operation of the heater. The main factors that affect the burning characteristics of firewood are moisture content, tree species and piece size.

The moisture content of the wood affects the rate at which it burns and the efficiency of combustion. When trees are cut, the wood moisture content ranges between 35 and 60 per cent by weight. If you attempt to burn wood this wet it will be hard to ignite, slow to burn and will hiss and sizzle in the firebox. So much energy will be consumed in boiling off the excess water that the efficiency of combustion and the heat to your home will be low, condensation and corrosion may be occurring in the flue and smoke may be causing problems to your neighbours. Properly seasoned wood ignites readily and burns efficiently.

**PLEASE NOTE: WOOD WITH A MOISTURE CONTENT OF 25% OR LESS IS THE ONLY APPROVED WOOD TO USE IN CLEAN AIR ZONES. ONLY SOFTWOODS SHOULD BE USED IN THE CANTERBURY CLEAN AIR ZONES.**

**Firewood should be cut and split in the early spring and stacked under cover, with good ventilation, to be ready for burning when required.**

Look for checks or cracks in the end grain as a sign of dry wood. The stacks of firewood should be in an open area so that air can circulate through them. During the summer, as warm breezes flow through the stacks, carrying away the evaporating water, the moisture content of the wood will fall to around 20 per cent. At this moisture content the wood is ready for burning.

Although the energy content of dry wood per kilogram is almost the same regardless of species, some burn differently because of differences in density e.g pine is less dense than woods like gums, Manuka or Black Wattle. A denser wood will produce a longer-lasting coal bed, while a less dense wood will bring a fire to an optimum burning temperature more quickly.

The size of the firewood pieces affects the rate of combustion. Larger pieces ignite and release their energy more slowly than small pieces. Smaller pieces are better for short, hot fires and larger pieces are preferable for extended firing cycles. In general, commercial firewood dealers supply firewood in thicker pieces than modern wood-burning heaters can handle. It is often necessary to split some of the wood again before using it. The thickest piece size for high-efficiency heaters should not exceed about 150mm (6 in.) across the largest dimension and a range of smaller pieces will be needed for effective stoking. Maximum log length varies according to model.

## **BURNING COAL**

Due to their construction, the burning of coal in Jayline solid fuel heaters is prohibited. Please also refer to 'Exclusions' in the Warranty Page 16.



## JAYLINE WOOD FIRE MAINTENANCE

***To keep your fire burning clean and efficient it is important that you carry out regular maintenance. General maintenance checks should include the following:-***

**ASH REMOVAL** – Due to the high efficiency of your Jayline fire, ash removal should only be necessary every few weeks. Ashes can be removed easily through the fire door when the fire is at its lowest, such as first thing in the morning, or when it is completely out. Always use a metal container to remove ash from your fire as ash can maintain high temperatures for several days. Jayline fires work best when a small amount of ash (approximately 20mm deep) is left in the firebox after cleaning. This insulates the bottom and prevents the base of the firebox overheating and burning out. In fact, building up the ash bed helps extend the long burn cycle, while reducing the ash bed encourages greater heat output.

**SURFACES** – Jayline wood fires have high temperature painted surfaces which just need wiping to clean when the fire is cold.

**FIREBOX** – Check the firebricks, top baffle and interior surfaces. These parts are subjected to considerably high temperatures and stress and some parts will eventually need replacing.

**DOORS** – Check all gaskets used for wear and replace if necessary. Adjust door fitting if required.

**LUBRICATION** – All moving parts should be lubricated with graphite grease every couple of months.

**REMOVAL OF FASCIA FOR CLEANING** – The fascia is held on to the fire box outer case by 4 ball studs, that are all pushed into locating holes and clips. It is important to remove the fascia carefully so as not to scratch the hi-temp paint. Instructions on how to do this follow:

- \* Remove the air control knob by jiggling side to side while pulling.
- \* The fascia only needs to come out by 10-20mm so to do this, leave the firebox door closed, place both hands under one side of the ash lip and pull firmly, then pull the other side. Be sure not to pull too far, as you only need to unlock the ball studs.
- \* Once the bottom studs are free, place your fingers behind the fascia near the top at each side and pull toward you – again only 10-20mm.
- \* Now the fascia is unlocked from the ball studs you will need to open the fire box door so the handle won't damage the paint on the fascia as you take it away from the firebox.
- \* Now the fascia is off, remove any items that should not be around the firebox (a torch will help you see into the dark space), then vacuum away any dust and debris etc.
- \* Re-install the Fascia in the reverse order and give the fascia a firm push at all 4 corners to ensure a secure fit.



## CHIMNEY CLEANING AND CHECKING FLUES

For all wood fires, flue cleaning must be done regularly to avoid serious flue fires. Frequently used fires should be cleaned at least once a year (some sooner). The cleaning rate, however, depends on the burning habits of the individual operating the wood fire. For example, it is possible to clog a flue in just a few weeks if smouldering fires are burnt and the flue is run cold.

It is recommended that flue sweeping be done by a professional chimney sweep. Chimney sweeping is a specialist task and competent professional sweeps are available throughout the country. When the flue is cleaned it is recommended that other parts, such as baffles, are checked.

Flue systems should be checked at least once or twice a heating season. Flue systems may require checking more often if the fuel or operation of the appliance is incorrect. When a flue system becomes excessively blocked or requires frequent cleaning, advice should be sought to investigate the installation and the operation of the fire. Flue pipes can deteriorate very quickly with incorrect firing.

## CONSUMABLES

Some parts of your Jayline fire are considered consumable. They are designed to be replaced as they will degrade over time. The life of the consumables will vary depending on;

- Frequency of use. How often the fire is used
- Rate of burn. Is the fire burning on low or high the majority of the time
- Type of fuel. Some woods are much harsher than others
- Level of ash. High levels of ash can push embers up and over rear air tubes

General items that are considered consumables:

- Baffles
- Fire bricks
- Air tubes
- Glass and door ropes

It is very important that you replace these parts when they show sign of wear. They effect how the fire runs and you may increase your fuel consumption or lower your efficiency if not replaced, and can in some cases, damage the firebox. It is generally obvious once a part is in need of replacement. Steel components may split or large holes may appear, fire bricks may crack and disintegrate. We recommend you check your fire visually several times a year for damaged components.



## WARNINGS

Below is a list of warnings to ensure efficient and safe operation of your Jayline wood fire:

- **WARNING:** DO NOT USE FLAMMABLE LIQUIDS OR AEROSOLS TO START OR REKINDLE THE FIRE.
- **WARNING:** DO NOT USE FLAMMABLE LIQUIDS OR AEROSOLS IN THE VICINITY OF THIS APPLIANCE WHEN IT IS OPERATING.
- **WARNING:** DO NOT STORE FUEL WITHIN APPLIANCE INSTALLATION CLEARANCES.
- **WARNING:** OPEN AIR CONTROL BEFORE OPENING FIRE DOOR.
- **CAUTION:** THIS APPLIANCE SHOULD NOT BE OPERATED WITH A CRACKED GLASS.
- **CAUTION:** THIS APPLIANCE SHOULD BE MAINTAINED AND OPERATED AT ALL TIMES IN ACCORDANCE WITH THESE INSTRUCTIONS.
- **CAUTION:** THE USE OF PRESERVATIVE-TREATED WOOD OR DRIFTWOOD AS A FUEL CAN BE HAZARDOUS.

