



JAYLINE IS550 ZERO CLEARANCE CABINET

INSTALLATION INSTRUCTIONS

JAYLINE IS550 ZERO CLEARANCE CABINET

Congratulations on the purchase of your Jayline IS550 wood fire and ZC Cabinet.

INTRODUCTION

Please read the entire manual before commencing the installation.

The Jayline IS550 wood fire ZC Cabinet system have been tested together and complies with AS/NZS 2918:2001, AS/NZS 4012:1999 & AS/NZS 4013:1999 when installed in accordance with this manual. Correct installation is critical to the safe operation and performance of this fire.

For your safety, the building regulatory Authorities in New Zealand require any wood fire installation to comply with Installation Standard AS/NZS 2918:2001. They may also have local requirements in addition to those in the Standard. Check with your local Building Authority before commencing the installation to find if you require a Building Consent and whether there are extra requirements.

As the safety and emission performance can be affected by altering the appliance, no modifications are allowed without written permission from the manufacturer.

Jayline recommends the installation only be carried out by a suitably qualified installation technician. Your dealer or heating specialist will be able to help with recommendations as well as advice on permits / consents required for the installation in your area. Please ensure you have all relevant permits prior to installation.

CAUTION!

Inspect the house construction at the proposed installation position to verify the flue / liner system will pass through the house without requiring the removal of essential roof or ceiling support beams. A minimum overall length of 4600mm, of flue pipes and casings must be used above the floor of the appliance to ensure the correct performance of this fire and ZC Cabinet installation. This comprises of 150mm diameter flue pipes, 200mm diameter inner liners and 250mm diameter outer liners. Deviation from this may alter the heaters performance and may nullify the Jayline warranty if the flue is excessively long or short. If in doubt, contact your Jayline dealer.

- The ZC Cabinet must be secured to the floor / floor protector prior to the firebox being fitted.
- All flue and liner joints must be riveted. The bottom of the flue must be fully sealed into the flue spigot and secured through the hole in the spigot.
- The fire must be bolted securely to the floor to comply with the seismic restraint provisions of AS/NZS 2918:2001.



STEP 1 - UNPACK AND FAMILIARISATION

The function of the ZC Cabinet is to enable the firebox to be installed into a timber framed wall, replacing a masonry chimney at a fraction of the cost.

Unpack the items supplied and familiarise yourself with them.

Supplied with the Jayline IS550 ZC Cabinet are:

- 1 x Assembly and installation instructions
- 1 x Outer Cabinet assembly
- 1 x 200mm / 250mm liner assembly stub
- 1 x Fascia spacer frame (3 pieces)
- 1 x Firebox / Cabinet alignment tool
- 1 x Fastener pack
- 2 x Thermal insulation strips

Items not supplied:

- 2 x Seismic Restraint fixtures (masonry anchors or wood screws)
- 150mm diameter flue pipe
- 200mm / 250mm liners
- Flue / Liner spacer brackets
- Cowl
- 250mm or 300mm diameter flashing
- Roof flashings
- Non-combustible facade capping
- Non-combustible materials used elsewhere
- Timber and lining products
- Floor Protector / Hearth materials
- Vent / Vents
- Other items as required
- Various fasteners and products dependant on build type

STEP 2 – VENTING

An air vent or vents are required on the rear of this installation to ensure an air flow can be maintained in the enclosed cavity as shown in fig 1 & 2. The bottom edge of the lower vent or vents must be no more than 100mm above the floor and have a minimum surface area of 10,000 square mm e.g. a meshed vent of 200 x 100mm. The vent area must be kept clear at all times and vermin proofed.



STEP 3 – CEILING AND ROOF

Prepare the ceiling / penetration / roof, false chimney and venting (top or side required) to enable the 250mm outer casing to be easily fitted prior to the cavity frame being completed as per fig 3 & 4.

The distance from the front edge of the enclosure (non-combustible lining directly behind the fascia) to the centre of the flue is 365mm as per fig 8. Please allow for any other material being used at the front, such as bricks etc.

STEP 4 – PREPARING THE WALL OPENING / CAVITY

Framing out – figures 5, 6, 7 & 11

- All timber framing and cladding must comply to NZS: 3604
- If the enclosure is constructed to the full height of the room, and is fully open / vented into the ceiling cavity of the house, then the enclosure must be vented as per fig 3.
- If the ZC Cabinet is built into an enclosure that is not open / vented to the ceiling cavity, the enclosure must be vented as illustrated in fig 4.
- The timber frame opening (front) must be a minimum of 1160mm high (above the floor protector) x 850mm wide x 645mm deep, as shown in fig 7 & 11.
- The enclosure cladding should only be fitted once the ZC Cabinet, firebox and flue system has been fitted and checked.
- The cladding immediately behind the fascia must be made from 9mm Promina board (or thermal equivalent), refer to fig 9 & 12.

Please note fire rated Gib board is not an acceptable material.

- The enclosure cladding should only be fitted once the ZC Cabinet, firebox and flue system has been fitted and checked.
- The remaining enclosure cladding can be standard cladding materials.
- Please be aware the wall surfaces directly above the heater may reach 850C, so materials such as wallpaper and water based paint may be adversely affected by heat. For durability of finishes and surfaces you should contact the relevant manufacturer for their specifications and advice.
- The internal areas of the enclosure do not require cladding or insulation.
- Install the lower vent into the rear of the cavity (required) as per fig 1 & 2.
- Install the upper vent (top or side requirements depend on type of construction) as per fig 3 & 4.



STEP 5 – FLOOR PROTECTOR

- 2 x layers of 9mm Promina, fig 12 (or thermal equivalent) insulation is required under the ZC Cabinet. The ZC Cabinet may not sit directly onto a timber or particle board floor, or combustible spacer. Please note: Raise the firebox to suit the required floor protector height (including decorative tiles etc).
- Please refer to fig 14 for the ZC Cabinet floor protector requirements.

STEP 6 – INSTALLING THE JAYLINE IS550 ZC CABINET

- Please ensure the floor / base is flat and level for the ZC Cabinet to sit on.
- Be sure to maintain the minimum air gap to combustibles inside the cavity as shown in fig 8.
- Use 2 layers (minimum) of 9mm Promina Board, fig 12 (or thermal equivalent), 800mm wide x 620mm deep under the ZC Cabinet.
- Please note: The floor protector must be the same height as the bottom of the ZC Cabinet to ensure the fascia will fit correctly (including decorative tiles etc).
- Slide in the ZC Cabinet until the folded front edges are flush with the front framing timber and are central within the cavity.
- Drill & screw the ZC Cabinet to the floor within 50mm of each corner.
- Remove the door and air control knob from the firebox.
- Fit the firebox into the ZC Cabinet.
- Use the Firebox / Cabinet alignment tool to centralise and set the depth of the firebox into the ZC Cabinet. If used correctly, the firebox will be central, and will extend 19mm in front of the ZC Cabinet.



- Drill the holes for the seismic restraint bracket (2) located at the front of the firebox, being careful not to alter the unit's location. Re-check all measurements and settings, then fit and tighten two 6mm x 50mm dyna bolts.
- Fit the 2 x thermal insulation strips directly above and in-between the top of the firebox outer case as per fig 10.



STEP 7 – FLUE SYSTEM

- Fit the 200mm / 250mm liner assembly stub central to the hole in the top of the ZC Cabinet using the self-tapping screws (supplied), and fix to the top of the ZC Cabinet.
- When fitting the 150mm diameter S/S flue pipes, 200mm diameter Galv inner liners & 250mm Galv outer liners, use only flue components that comply with AS/NZS 2918:2001.
- As the flue system is assembled from the firebox up, one length at a time, start with the 150mm S/S flue pipe. Ensure the first length is fastened and sealed to the firebox. Use the hole provided at the front of the firebox flue spigot. All 150mm S/S flue pipes must be sealed and riveted together using at least 3 x S/S rivets in each joint.
- As the 3 different diameters are joined, one length at a time, use S/S spacers between the S/S flue pipe and liners to ensure the correct spacing. All flue pipes and liners require at least 3 x S/S rivets at each joint.
- Depending upon the type of false chimney / termination being used, will determine the type of cowl and casing cover being used. This will also dictate the type of venting to use, refer to fig 3 & 4.
- Once the flue system has been fitted and checked, a 25 x 25 x 5mm angle iron support (or similar non-combustible support) should be secured to the framing, 750mm above the floor protector to support the area directly behind the top of the fascia, refer to fig 10 & 11.
- Now the cavity can be clad prior to the fascia being fitted, as mentioned above in Step 4.

STEP 8 – FITTING THE FASCIA AND FASCIA SPACER

- Carefully fit the Fascia spacer frame (3 pieces) together using cotton gloves, so as not to mark the paint. Locate over the 4 x ball clips and centralise if necessary. The spacer frame is not screwed together, but is held in place by the fascia.
- Carefully lift and fit the fascia (not under the grill blades) using cotton gloves. Locate centrally over the ball studs and gently push onto the studs until all are secure.
- Check the fit of all parts to ensure there are no gaps large enough, to cause a draught or heat loss.
- Re-fit the door and air control knob.

STEP 9 - MANTLE DETAILS

A mantle can be made from combustible materials and made using the minimum / maximum sizes as per fig 14.



FIGURE 14

FLOOR PROTECTOR REQUIREMENTS

Height of top of floor protector above the exposed floor (mm)	Projection (mm) From glass Remember the glass extends 80mm from the face of the 9mm Promina board	Projection (mm) From 9mm Promina board
0	525	605
20	480	560
40	427	507
60	380	460



Figure 1

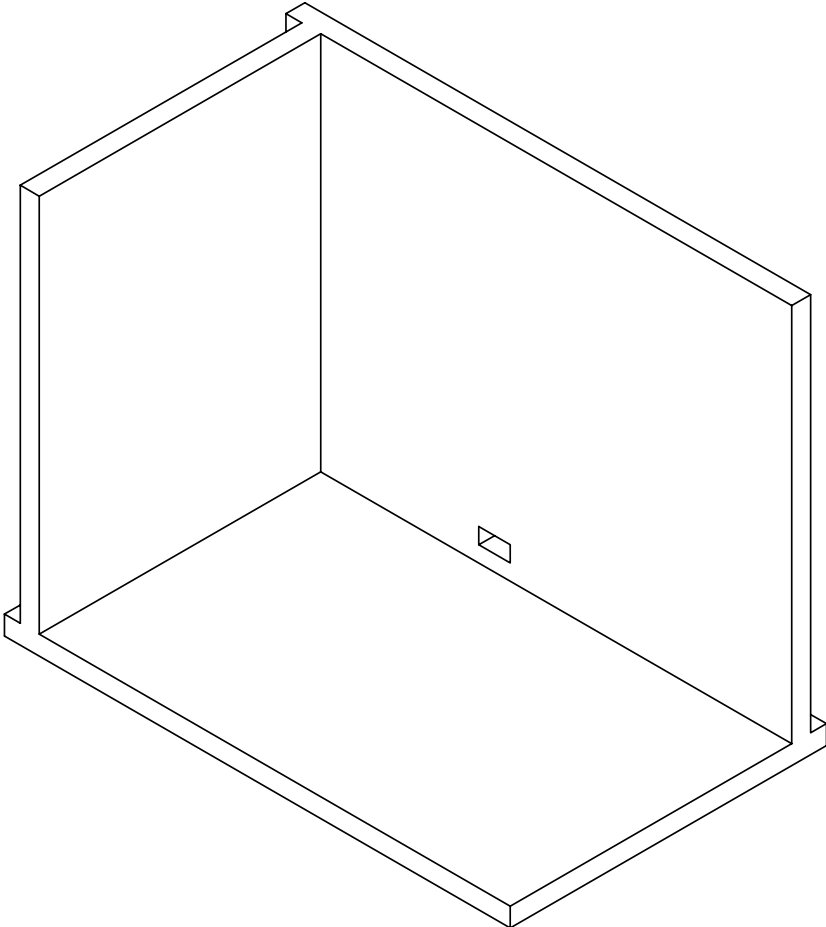
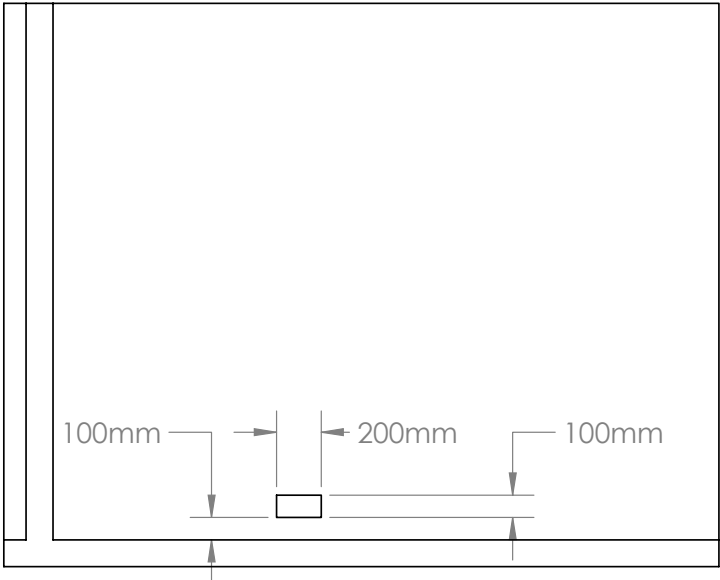

Figure 2



AN AIR VENT OR VENTS ARE REQUIRED ON THE REAR OF THE ENCLOSURE AND MUST BE VENTED TO OUTSIDE AIR. THE BOTTOM EDGE OF THE LOWER VENT OR VENTS MUST BE NO MORE THAN 100mm ABOVE THE FLOOR AND HAVE A MINIMUM SURFACE AREA OF 10,000 SQ mm E.G. 200 X 100mm. THE MESHED VENT MUST BE KEPT CLEAR AT ALL TIMES AND VERMIN PROOFED.



Figure 3

FALSE CHIMNEY VENTED THROUGH 150-350 CASING COVER

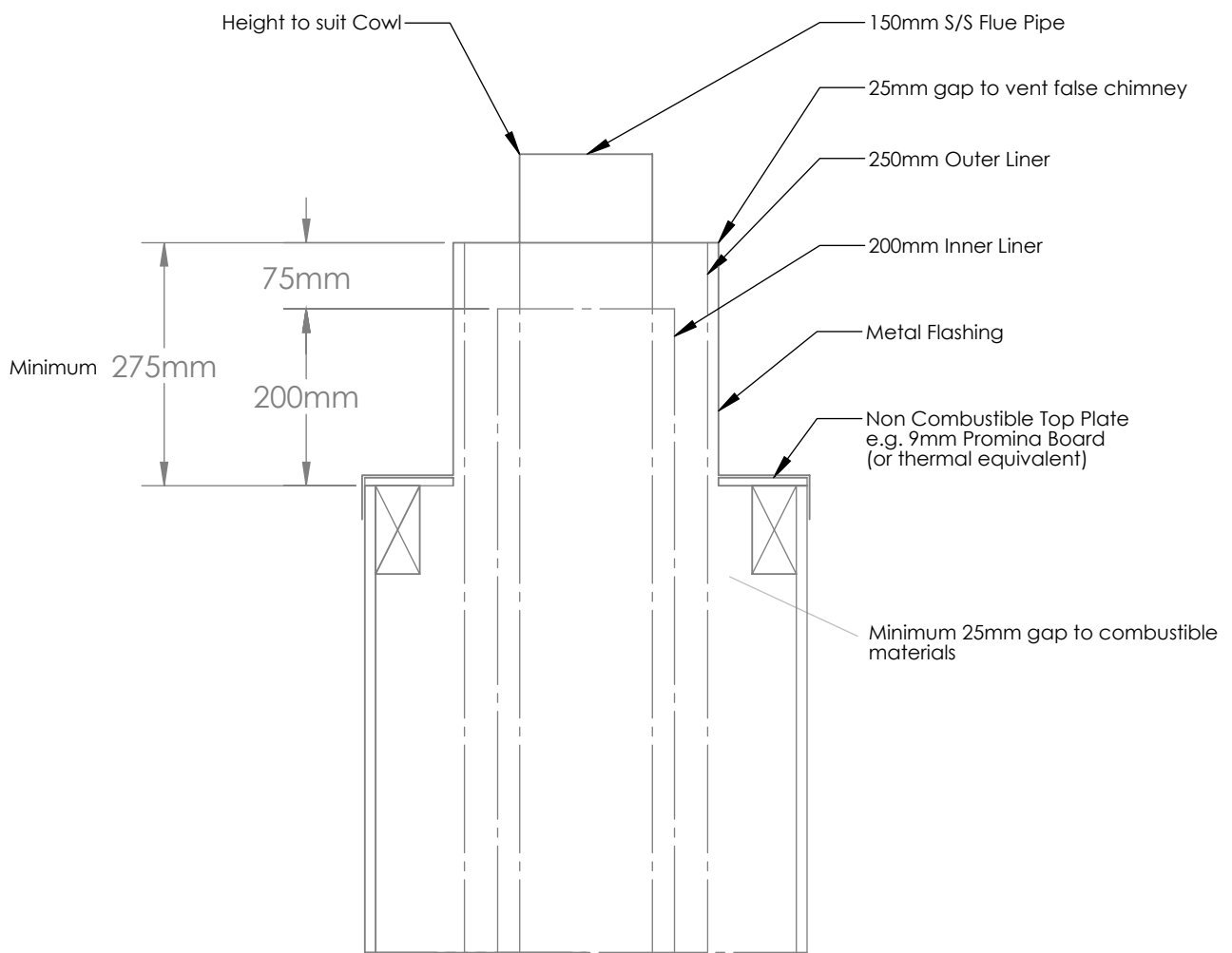

NOTE: IT IS VERY IMPORTANT THAT THE SPACE BETWEEN THE FLUE PIPE, INNER CASING AND OUTER CASING ARE VENTED AT THE TOP.



Figure 4

FALSE CHIMNEY VENTED THROUGH SIDE VENT

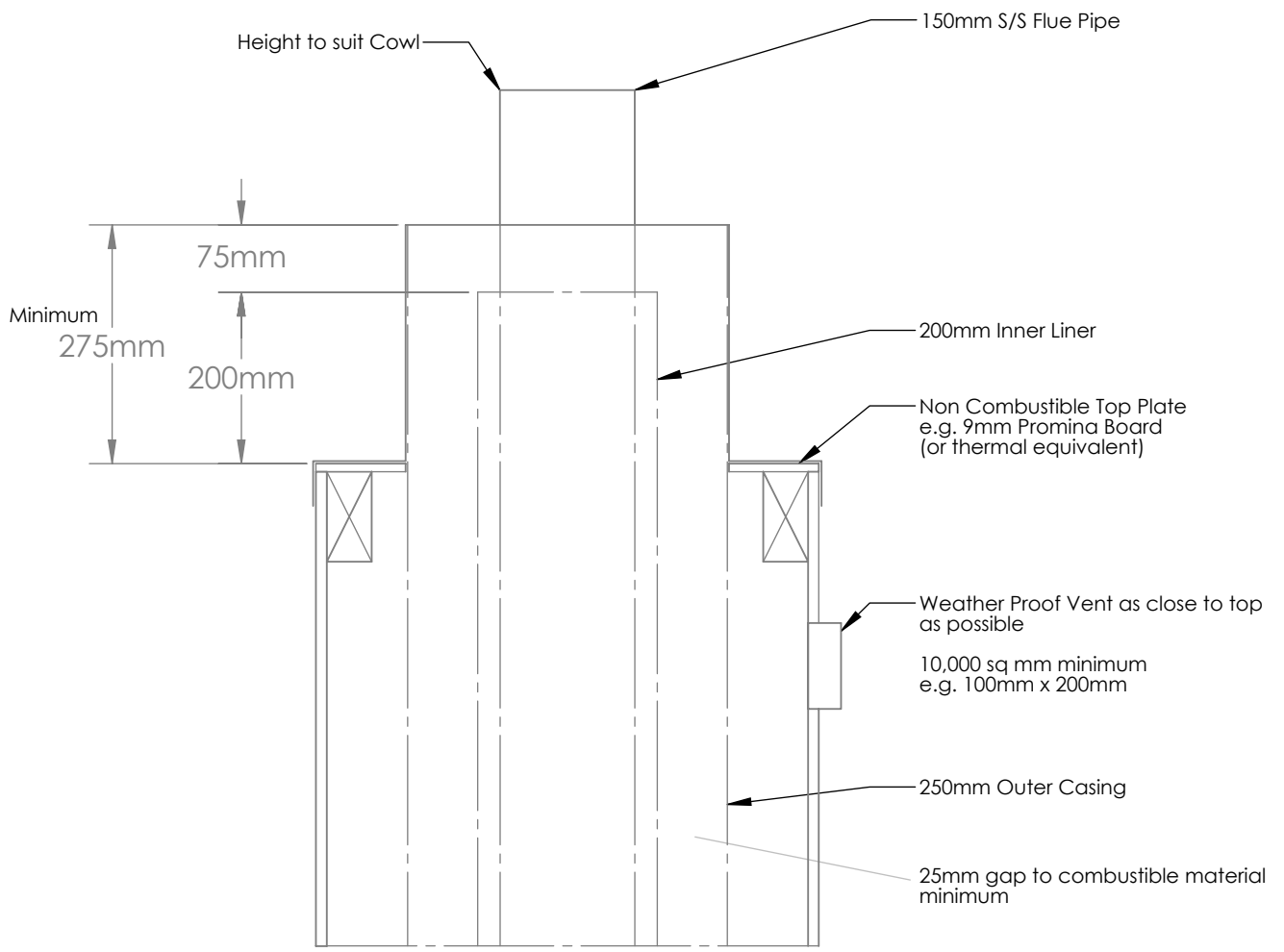

NOTE: IT IS VERY IMPORTANT THAT THE SPACE BETWEEN THE FLUE PIPE, INNER CASING AND OUTER CASING ARE VENTED AT THE TOP.



FIGURE 5

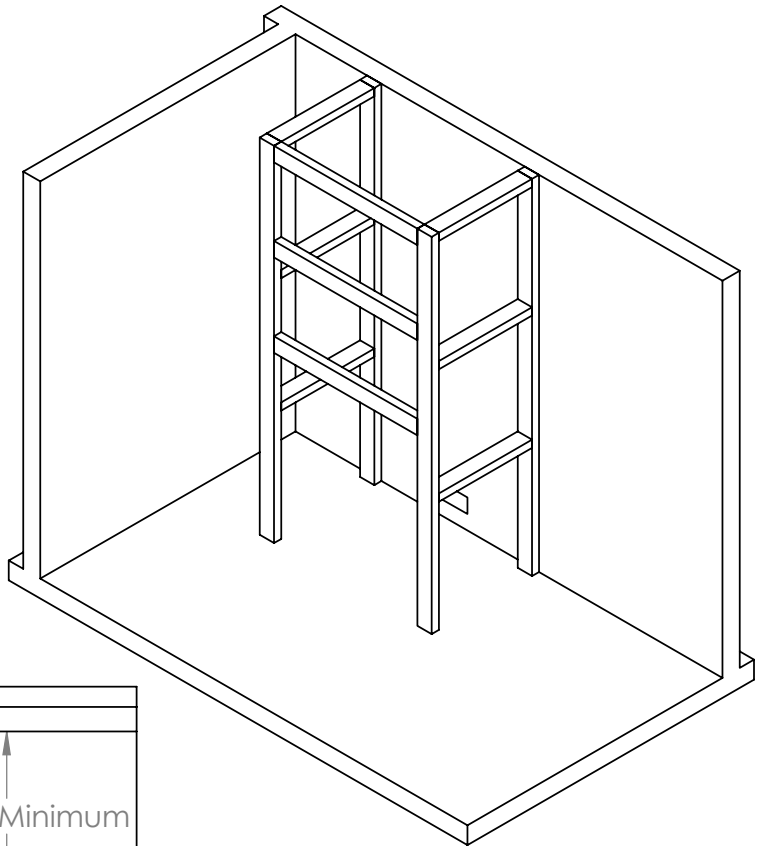

FIGURE 6

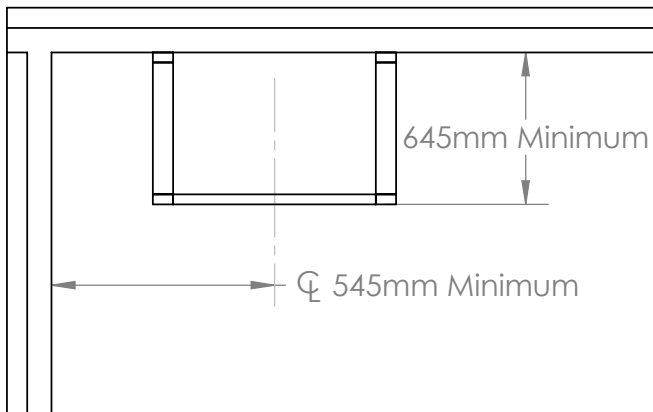
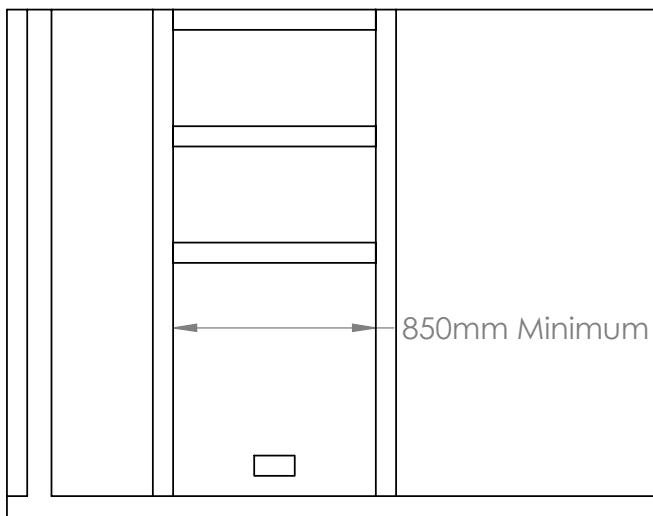

FIGURE 7



FRAMING REQUIREMENTS AS PER NZS:3604 (SHOWING MINIMUM REQUIREMENTS)



Figure 8

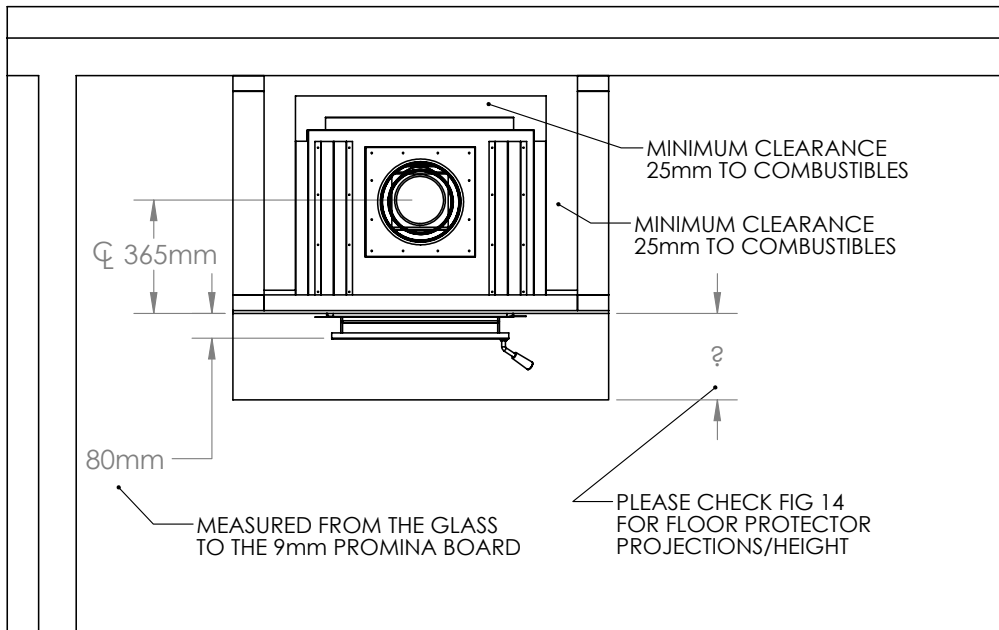

Figure 9

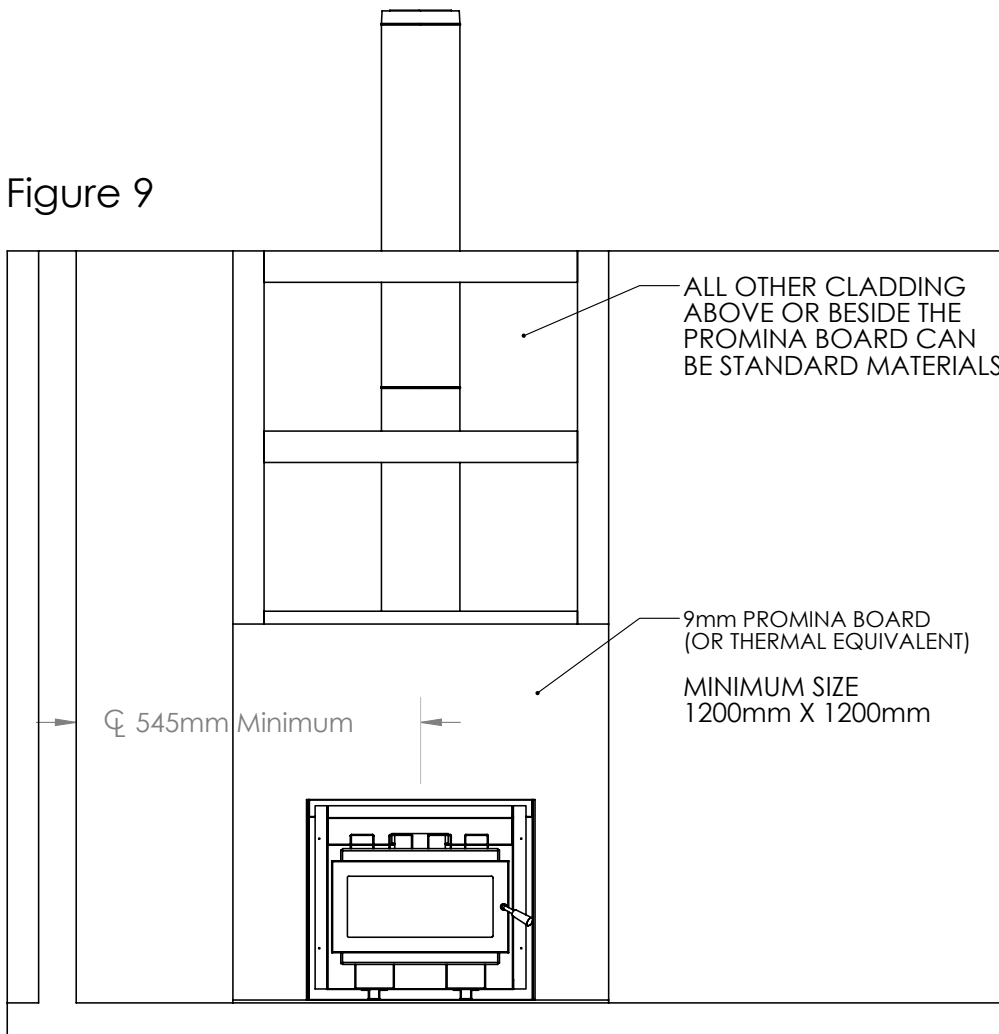
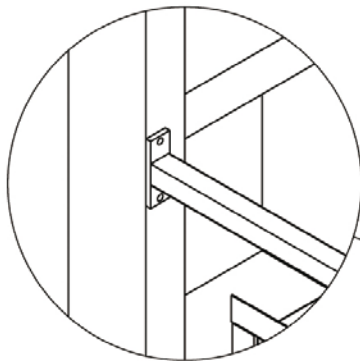

Figure 10



DETAIL A
SCALE 1 : 6

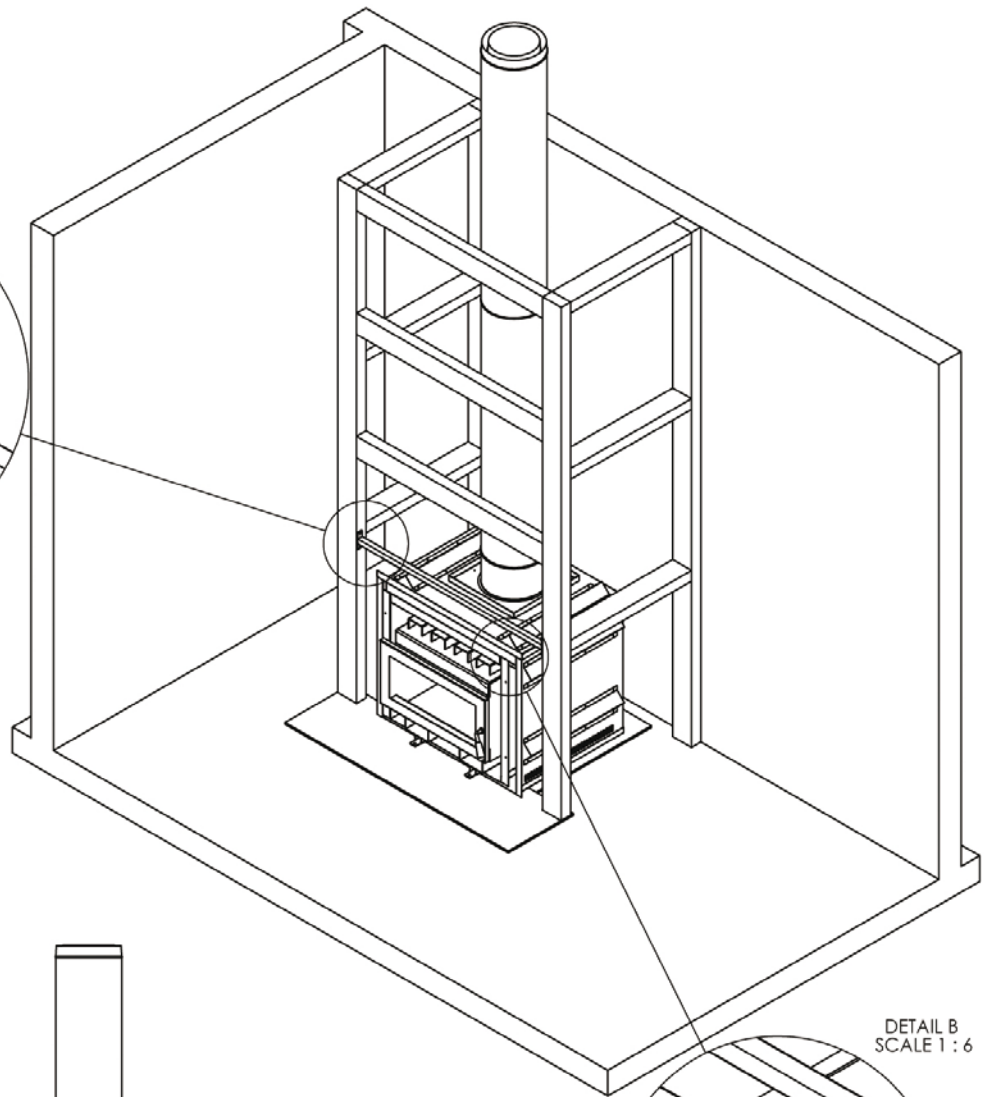

Figure 11

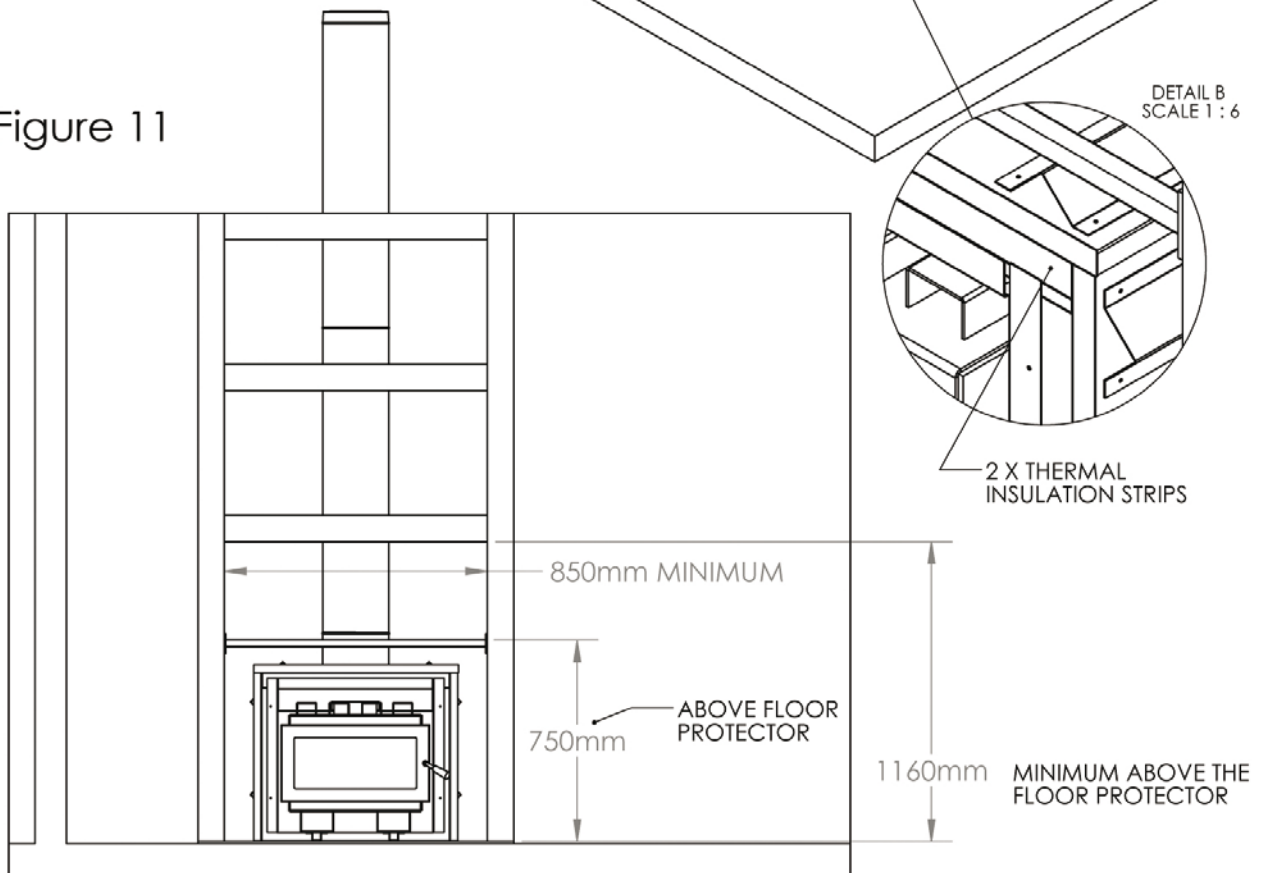

Figure 12

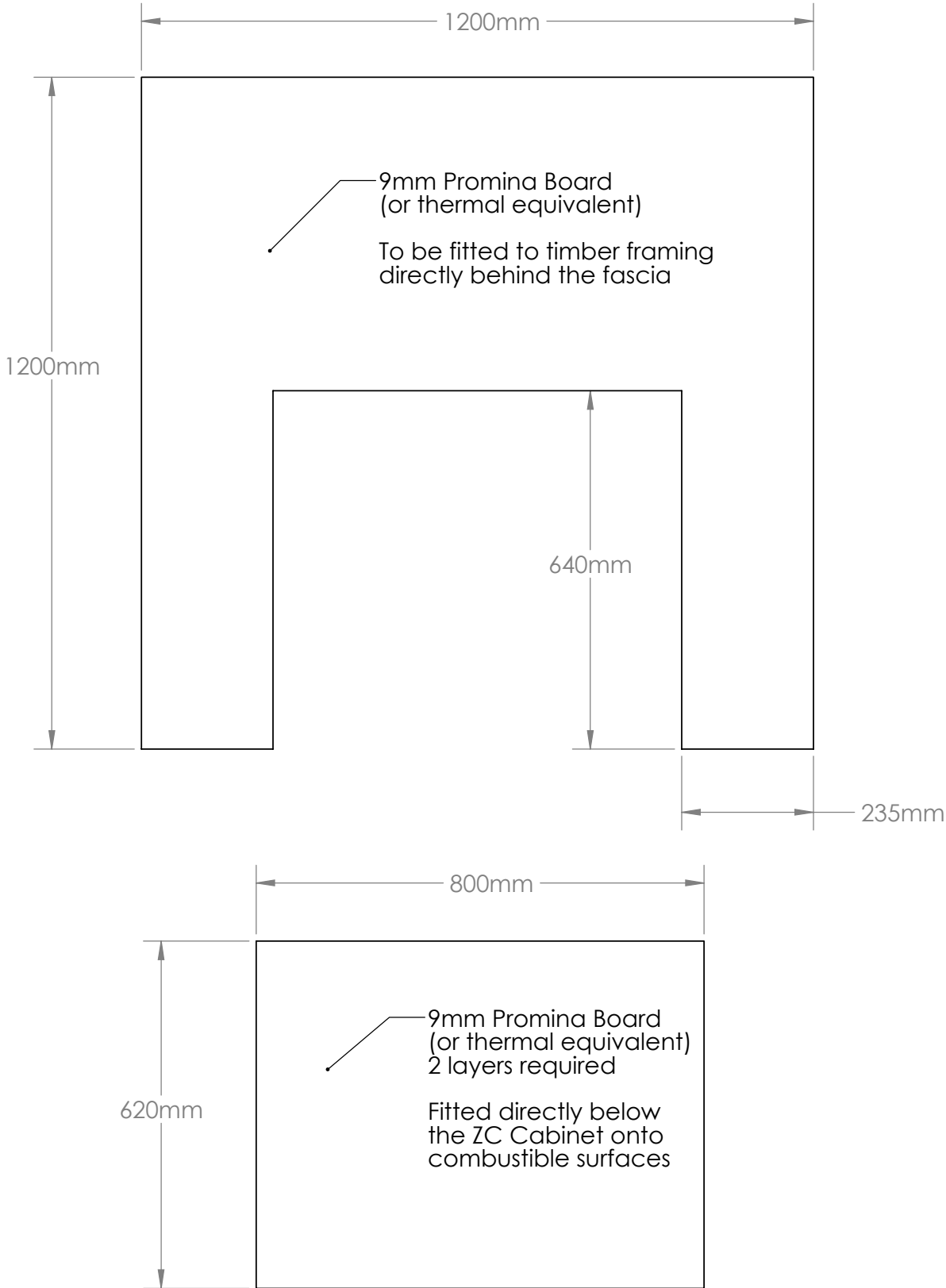

Figure 13

Mantle Requirements

